



ZORLU DEĐİRMEN

DEĐİRMEN MAKİNELERİ İML. SAN. LTD. ŐTİ.

ÜRÜN KATALOĐU | PRODUCT CATALOGUE





ZORLU
DEĞİRMEN

TAŞIMA
HANDLING
ТРАНСПОРТИРОВКА



ELEVATÖR

Elevator
Элеватор

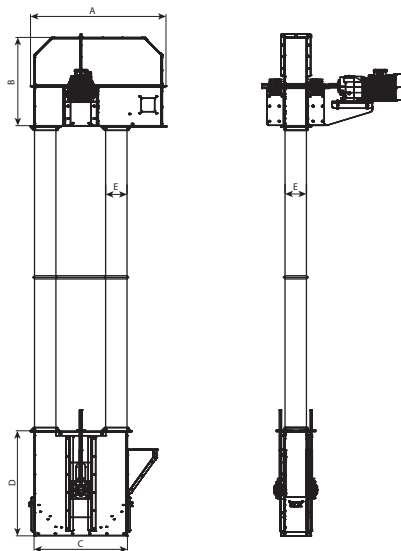
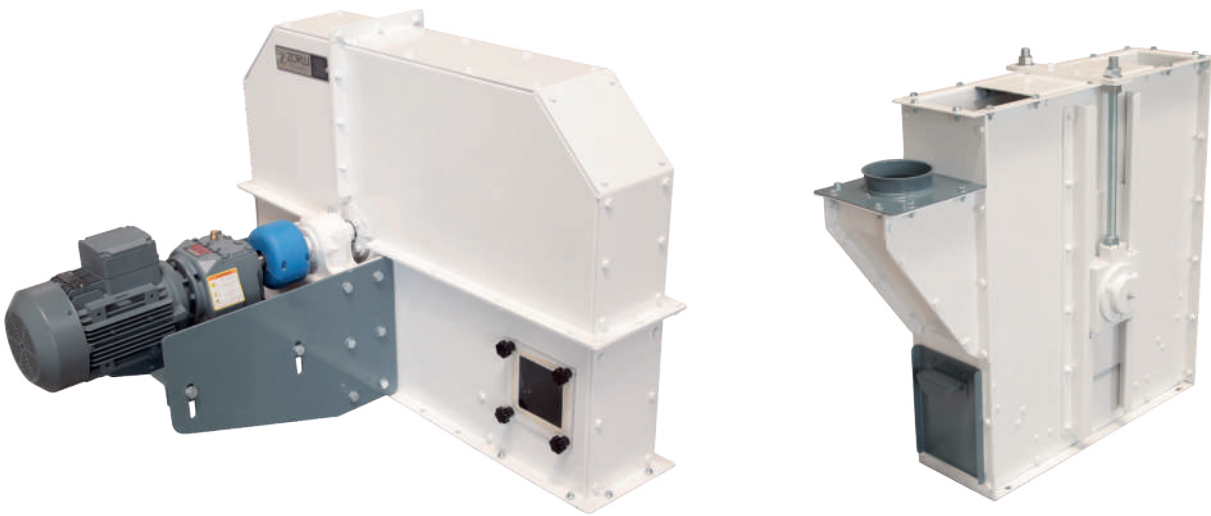

Type	Technical Features Motor (kW)	Dimensions (mm)				Weight (kg)
		A	B	E	H	
ZEL 16x16	0,75	785	700	570	160	164
ZEL 20x20	1,1	1100	830	750	200	245
ZEL 22x22	1,5	1116	830	790	220	293
ZEL 25x25	3	1220	855	950	250	428
ZEL 30x30	4	1520	1075	1120	300	757
ZEL 30x35	5,5	1520	1075	1120	350	870

ZEL-101 Elevatör Kovaları (Metal)

Elevator Buckets (Sheet)
Ковш Нории (Металлический)

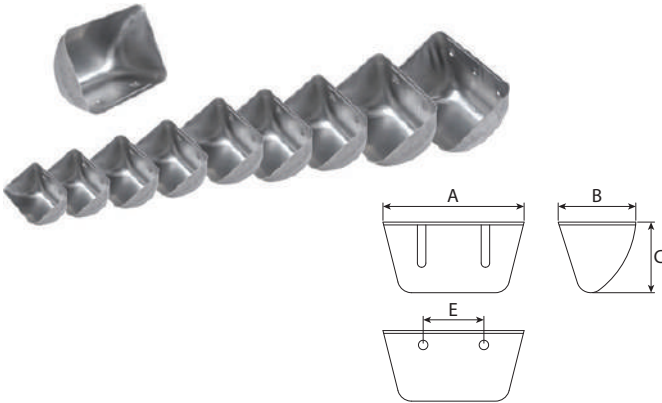

Code	Type	Dimensions (mm)					Lt.	Kg.
		A	B	C	E			
ZEL -101	90	98	95	71	46	0,310	0,250	
	100	110	103	77	57	0,370	0,325	
	120	126	114	87	67	0,585	0,510	
	140	148	133	96	85	0,820	0,750	
	160	170	143	103	101	1,140	1,035	
	180	188	148	110	110	1,270	1,240	
	200	209	160	136	130	1,730	1,550	
	225	235	166	133	140	2,345	2,315	
	240	240	175	130	120	2,505	2,252	
	250	260	168	137	154	2,755	2,590	
	280	280	180	115	190	2,950	2,770	
	300	310	180	136	205	3,890	3,680	
	320	320	220	150	200	6,251	4,474	

ZEL-102 Elevatör Kovaları (Plastik)

Elevator Buckets (Plastic)
Ковш Нории (Пластмассовый)

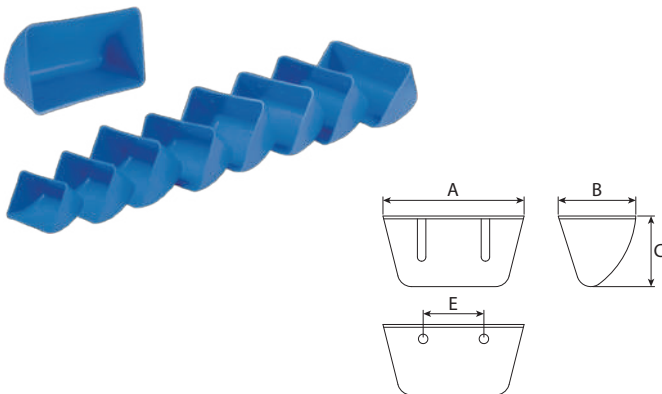

Code	Type	Dimensions (mm)					Lt.	Kg.
		A	B	C	E			
ZEL -102	100	107	100	75	46	0,242	0,330	
	120	125	115	85	57	0,382	0,510	
	140	145	135	95	85	0,581	0,750	
	160	165	145	105	101	0,775	1,040	
	180	185	145	110	110	1,006	1,250	
	200	205	160	120	130	1,588	1,550	
	225	230	165	130	140	2,101	2,320	
	250	260	168	135	154	2,505	2,600	
	280	295	195	140	190	3,455	2,800	
	300	315	200	150	205	4,221	3,700	
	320	340	212	160	215	5,022	4,250	

ZEL-103 Elevatör Kasnağı

Elevator Pulley
Шкив Нории



Code	Diameter (mm)
ZEL -103	250 / 150
	300 / 140
	300 / 160
	320 / 190
	400 / 220
	400 / 240
	500 / 260
	500 / 360
	600 / 280
	630 / 440
700 / 360	



ZEL-104 Elevatör Kayışları (Kauçuk)

Elevator Belts (Rubber)
Лента Нории (Каучуковая)



Code	Width (mm)	Layer									
		2	3	4	5	6	7	8	9	10	
ZEL-104	40	-	X	X	X						
	50	-	X	X	X						
	60	-	X	X	X						
	70	-	X	X	X						
	80	-	X	X	X						
	90	-	X	X	X						
	100	-	-	X	X	X					
	110	-	-	X	X	X					
	125	-	-	X	X	X					
	140	-	-	X	X	X	-	X			
	160	-	-	X	X	X	-	X			
	180	-	-	X	X	X	X	X			
	200	-	-	X	X	X	X	X			
	220	-	-	-	X	X	X	X			
	250-280	-	-	-	X	X	X	X			
	310	-	-	-	-	X	X	X			
	350	-	-	-	X	X	X	X			
	400-450	-	-	X	-	X	-	X	X	X	X
500-600	-	-	X	-	X	X	X	X	X	X	

ZEL-105 Elevatör Kayışları (Kauçuk)

Elevator Belts (Rubber)
Лента Нории (Каучуковая)



Code	Width (mm)	Layer					
		2	3	4	5	6	
ZEL-105	160	-	-	X	X	X	
	180	-	-	X	X	X	
	200	-	-	X	X	X	
	220	-	-	-	X	X	
	250-280	-	-	-	X	X	
	310	-	-	-	-	X	
	350	-	-	-	X	X	
	400-450	-	X	X	-	X	
	500-600	-	X	X	-	-	

ZEL-106 Kayış Zımba

Belt Punch
Дырокол Ленты Нории

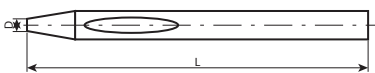

Code	Type	ØD (mm)	L (mm)			Code	Type	ØD (mm)	L (mm)			
ZEL-106	3	3	105	35	10	ZEL-106	17	17	140	365	5	
	4	4	105	40	10		18	18	140	380	5	
	5	5	110	50	10		19	19	145	405	5	
	6	6	110	60	10		20	20	145	450	5	
	7	7	115	75	10		21	21	150	250	5	
	8	8	115	90	10		22	22	150	260	5	
	9	9	120	100	10		23	23	160	305	5	
	10	10	120	110	10		24	24	160	320	5	
	11	11	125	130	5		25	25	170	365	5	
	12	12	125	165	5		26	26	170	365	5	
	13	13	130	165	5		27	27	180	415	5	
	14	14	130	180	5		28	28	180	420	5	
	15	15	135	245	5		29	29	190	465	5	
	16	16	135	300	5							

ZEL-107 SN Yataklı Rulmanlar

SN Bearing With Housing
Подшипник С Корпусом тип SN



Code	Type
ZEL-107	30 SN 507
	35 SN 508
	40 SN 509
	45 SN 510
	50 SN 511
	55 SN 512

Code	Type
ZEL-107	60 SN 513
	65 SN 515
	70 SN 516
	75 SN 517
	80 SN 518
	100 SN 522

ZEL-108 Elevator Kasnakları

Elevator Pulley
Шкив подъема



Code	Type	Bearin No			
		UCF	UCFL	UCT	UCP
ZEL-108	204	x	x	x	x
	205	x	x	x	x
	206	x	x	x	x
	207	x	x	x	x
	208	x	x	x	x
	209	x	x	x	x
	210	x	x	x	x
	211	x	x	x	x
	212	x	x	x	x
	213	x	x	x	x
	214	x	x	x	x
	215	x	x	x	x
	216	x	x	x	x
	217	x	x	x	x
	218	x	x	x	x

ZEL-109 Elevator Koko Civata

Elevator Flat Headed Bolts
Крепление Ковша Нории



Code	Type
ZEL-109	M8 x 30
	M8 x 40
	M10 x 30
	M10 x 40

ZEL-110 Kayış Macunu

Belt Paste
Паста Для Ремня (Смазка)





VİDALI HELEZON

Screw Conveyor
Шнек

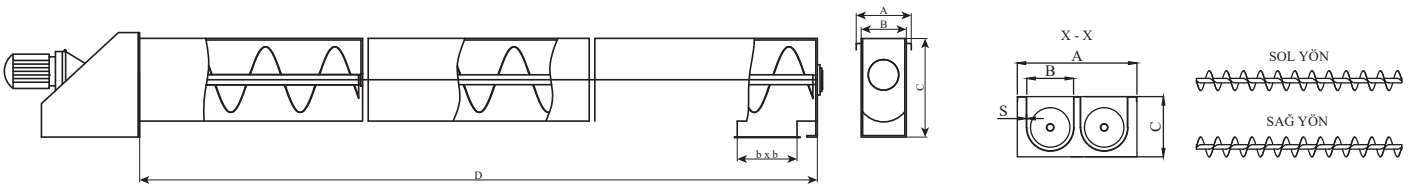

Type	Technical Features			Dimensions (mm)							Weight (kg)
	Capacity (t/h)			A	B	C	D	S	Q	H	
	Wheat	Flour	Bran								
ZRL - HLZ 165	4-7	3-4	1,6-2	275	195	265	42	2	165	165	24
ZRL - HLZ 180	6-9	4-6,5	1,8-3	290	210	280	42	2	180	180	26
ZRL - HLZ 200	8-13	5,5-9,5	2,5-4	310	230	300	48	2	200	200	28
ZRL - HLZ 220	9-15	6-10,5	3-5	330	250	320	48	2	220	220	35
ZRL - HLZ 250	15-25	11-18	5-8	360	280	350	60	2	250	250	45
ZRL - HLZ 270	16-27	12-20	6-9	380	300	370	60	2	270	270	48
ZRL - HLZ 300	25-45	18-25	8-16	410	330	400	76	2,5	300	300	50
ZRL - HLZ 350	65-70	45-50	25-30	460	380	450	90	2,5	350	350	56

TÜP HELEZON

Tube Screw Conveyor
Трубовидный Шнек

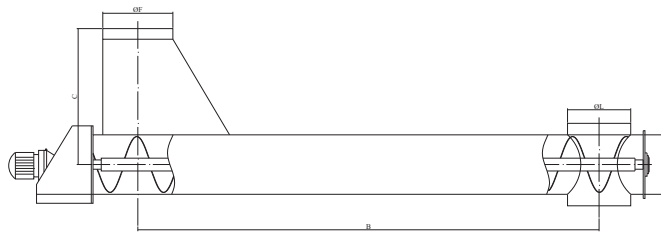

Type	Technical Features				Dimensions (mm)				Weight (kg)
	Dia Of Screw (mm)	Max. Length (m)	Capacity (t/h)		A	B	C	D	
			Flour	Bran					
ZTH 100	100	10	5	3	100	160	127	200	37
ZTH 145	145	10	6	4	145	200	168	215	40
ZTH 180	180	10	7	5	180	250	219	280	45
ZTH 220	220	10	15	10	220	305	276	270	52
ZTH 270	270	10	20	13	270	350	323	320	57

UN - KEPEK VİDASI

Flour - Bran Screw Conveyor
Мучной-Отрубной Шнек



Type	Technical Features			Dimensions (mm)							Weight (kg)
	Capacity (t/h)			A	B	C	D	S	Q	H	
	Wheat	Flour	Bran								
ZRL - UHLZ 165	4-7	3-4	1,6-2	450	190	265	42	2	165	165	48
ZRL - UHLZ 180	6-9	4-6,5	1,8-3	490	210	280	42	2	180	180	52
ZRL - UHLZ 200	8-13	5,5-9,5	2,5-4	530	230	300	48	2	200	200	56
ZRL - UHLZ 220	9-15	6-10,5	3-5	570	250	320	48	2	220	220	70
ZRL - UHLZ 250	15-25	11-18	5-8	630	280	350	60	2	250	250	90
ZRL - UHLZ 270	16-27	12-20	6-9	670	300	370	60	2	270	270	96
ZRL - UHLZ 300	25-45	18-25	8-16	730	330	400	76	2,5	300	300	104
ZRL - UHLZ 350	65-70	45-50	25-30	830	380	450	90	2,5	350	350	112



ZİNCİRLİ KONVEYÖR

Chain Conveyor
Цепной Конвейер

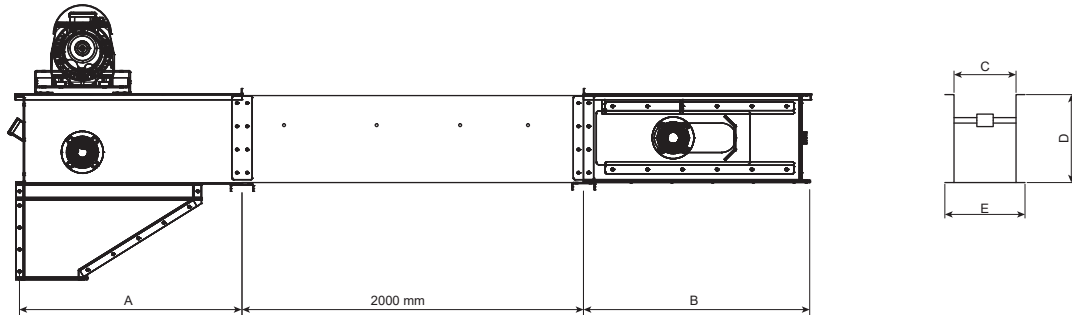
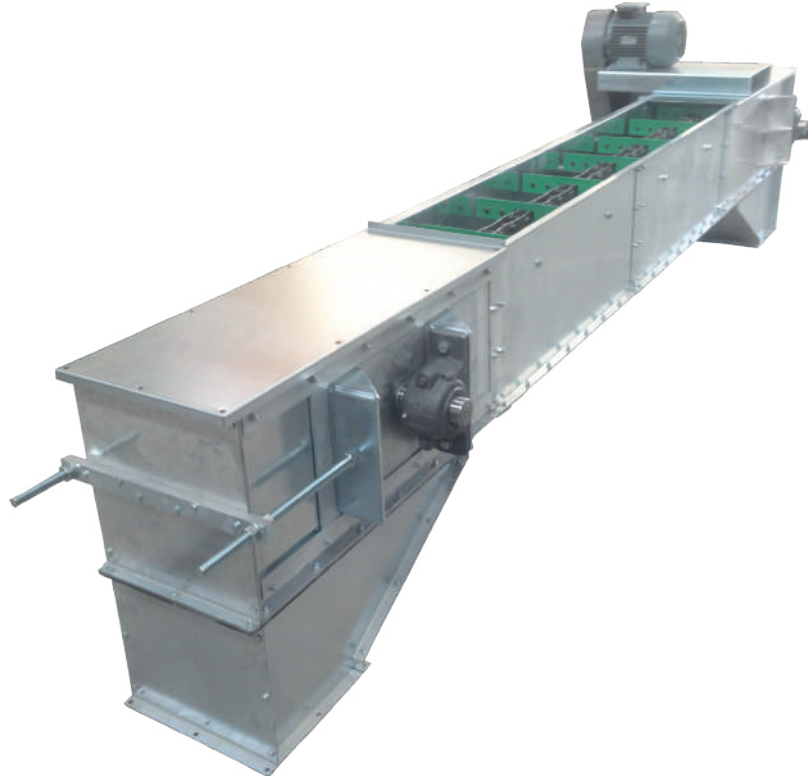

Type	Technical Features		Dimensions (mm)								
	Capacity (t/h)		A	B	C	E	F	G	H	J	K
	Wheat	Corn									
ZZK 50	50	40	510	290	800	256		180	735	840	1200
ZZK 100	100	85	510	690	800	306	430	230	860	840	1300
ZZK 150	150	125	510	690	800	381	430	305	890	840	1350
ZZK 200	200	170	510	690	800	416	430	340	925	840	1400
ZZK 250	250	210	510	690	800	506	430	450	1050	840	1540
ZZK 300	300	255	510	690	800	506	510	450	1050	840	1500

HLZ - 101 Helezon Yapađı

FlightSheet

Перо Шнека, Цельный, Холодный Прокат

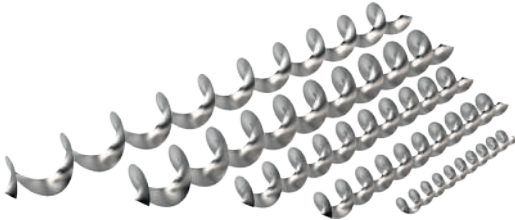
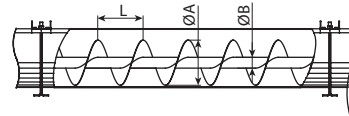

Code	ØA (mm)	ØB (mm)	L (mm)
HLZ-101-01	80	27	80
HLZ-101-02	100	27	100
HLZ-101-03	100	34	100
HLZ-101-04	125	27	125
HLZ-101-05	125	37	125
HLZ-101-06	130	27	130
HLZ-101-07	130	34	130
HLZ-101-08	145	34	145
HLZ-101-09	145	42	145
HLZ-101-10	145	49	145
HLZ-101-11	150	34	150

Code	ØA (mm)	ØB (mm)	L (mm)
HLZ-101-12	165	42	165
HLZ-101-13	180	42	180
HLZ-101-14	200	49	200
HLZ-101-15	200	60	200
HLZ-101-16	220	49	220
HLZ-101-17	250	60	250
HLZ-101-18	270	60	270
HLZ-101-19	300	76	300
HLZ-101-20	325	76	325
HLZ-101-21	350	90	350
HLZ-101-22	380	102	380

HLZ - 102 Helezon Askı Yatak (Ayaklı)

Screw Hanger Housing

Подвеска Шнека (Ножка)



Code	Diameter Ø (mm)
HLZ-102-01	40
HLZ-102-02	50
HLZ-102-03	60

HLZ - 103 Helezon Askı Yatak (Ayarlı Model)

Screw Hanger Housing (Adjust Model)

Подвеска Шнека (Регулирующая)



Code	Diameter Ø (mm)
HLZ-103-01	40
HLZ-103-02	50
HLZ-103-03	60

HLZ - 104 Helezon Askı Yatak (Gijonlu Model)

Screw Hanger Housing (Connector Model)

Подвеска Шнека (Разъемная)



Code	Diameter Ø (mm)
HLZ-104-01	40
HLZ-104-02	50
HLZ-104-03	60

HLZ - 105 Asma Yatak Burcu

Hanger Bearing Wedge

Прокладка Подвески Шнека



Code	Diameter Ø (mm)
HLZ-105-01	40
HLZ-105-02	50
HLZ-105-03	60



BLOWER POMPA

Blower Pump
Бловер Насос

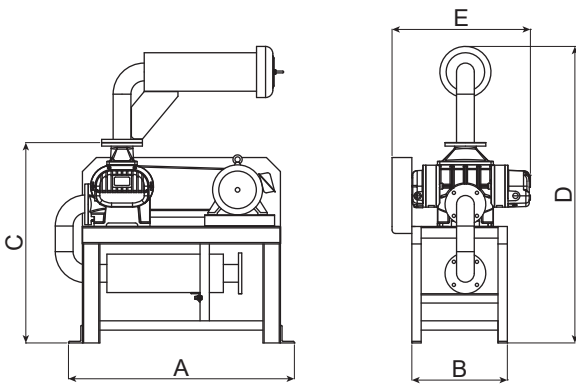

PNÖMATİK YÖN KLAPESİ

Pneumatic Direction Clamp
Пневматический Направляющий Клапан

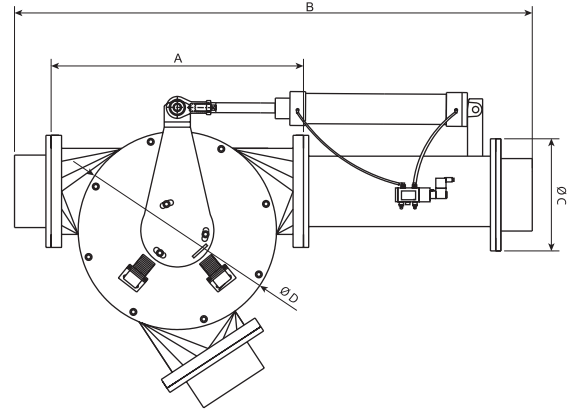

Type	Technical Features			Dimensions (mm)			
	Valve	Air Pressure (Bar)	Piston	A	B	ØC	ØD
ZPYK 50	5/2-24VDV/220-240v	6	32x115 mm	250	640	100	180
ZPYK 70	5/2-24VDV/220-240v	6	40x150 mm	310	690	130	225
ZPYK 95	5/2-24VDV/220-240v	6	50x180 mm	400	900	165	285
ZPYK 125	5/2-24VDV/220-240v	6	50x210 mm	485	985	195	370
ZPYK 135	5/2-24VDV/220-240v	6	50x260 mm	485	995	215	380
ZPYK 160	5/2-24VDV/220-240v	6	50x280 mm	530	1040	233	430

BLOWER HAVA KİLİDİ

Blower Air Lock
Шлюзовый Затвор Бловера

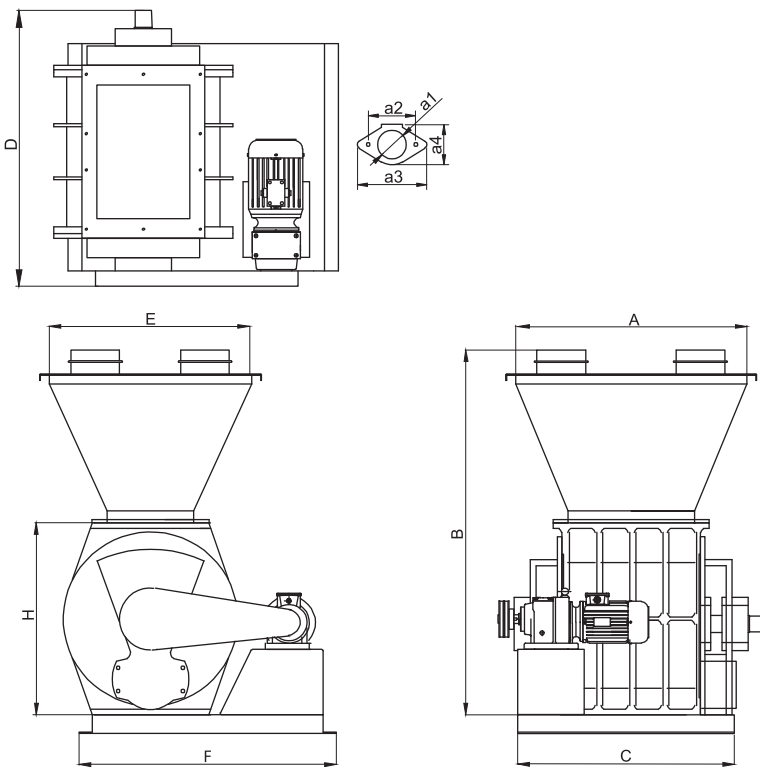

Type	Technical Features			Dimensions (mm)										
	Capacity (m³/h)	Motor (kW)	Shaft Dia (Ø)	A	B	C	D	E	F	H	a1	a2	a3	a4
ZBHK 200	0,37	4	28	350	700	275	540	370	230	330	57	110	160	80
ZBHK 250	0,55	10	28	450	750	375	600	400	260	380	70	135	166	100
ZBHK 320	0,55	22,7	42	700	900	550	700	450	750	445	100	160	210	132
ZBHK 450	0,75	51	42	800	1000	590	880	550	810	570	120	195	245	150
ZBHK 500	1,5	91	55	900	1275	640	1000	700	890	666	175	233	267	267

Maximum capacity has been calculated according to 65% occupancy rate



HAVA KİLİDİ

Air Lock

Воздушный Затвор

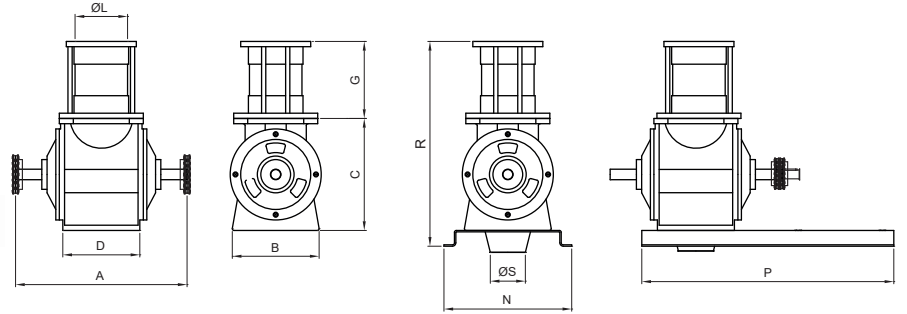

Model Type	Ölçüler / Dimensions (mm)										Ağırlık Weight (kg)
	A	B	C	D	G	L	N	P	R	S	
ZHK 200	490	250	295	220	220	132	365	720	515	120	40
ZHK 220	490	250	320	220	220	150	365	720	540	120	55
ZHK 240	490	250	320	220	220	150	365	720	540	120	65
ZHK 300	515	275	342	245	220	180	390	445	565	120	80
ZHK 400	590	390	480	340	220	200	440	485	700	200	135

PAÇAL MAKİNESİ

Blending Machine

Дозатор

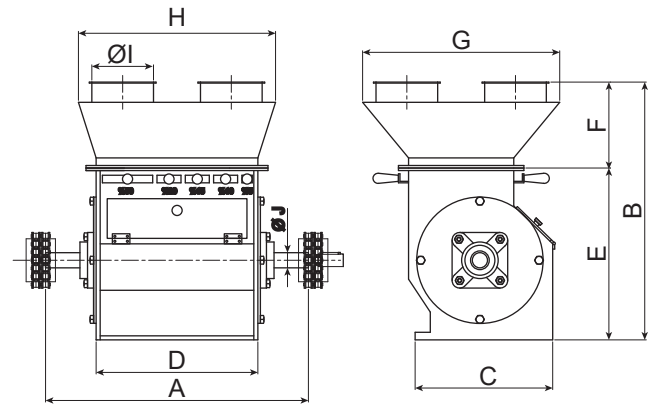

Model Type	Ölçüler / Dimensions (mm)										Kapasite Capacity (t/h)	Ağırlık Weight (kg)
	A	B	C	D	E	F	G	H	I	J		
ZPC 220	520	510	270	320	340	170	390	390	120	30	8-10	45

ZHK-101 Zincir Kaplin (Takım)

Chain Coupling (Set)
Цепная Муфта (Комплект)



Code	Type	1/2"	5/8"	3/4"	1"
ZHK-101	4020	x	-	-	-
	5018	-	x	-	-
	5020	-	x	-	-
	6020	-	-	x	-
	6022	-	-	x	-
	8020	-	-	-	x

ZHK-102 Zincir Kaplin

Chain Coupling
Цепная Муфта



Code	Type
ZHK-102	3/8"
	1/2"
	5/8"
	3/4"
	1"

ZHK-103 Yıldız Kaplin

Star Coupling
Звездобразная Муфта

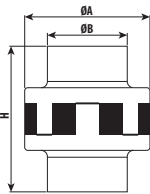

Code	Type	ØA	ØB	H
ZHK-103	90	80	51	93
	110	95	60	106
	130	110	72	116
	150	125	80	118
	180	140	93	131
	200	160	107	136

ZHK-105 Elastik Dişli Kaplin

Elastic Gear Coupling
Муфта



Code	Type
ZHK-105	DK 14
	DK 24
	DK 28
	DK 32
	DK 38

Code	Type
ZHK-105	DK 42
	DK 48
	DK 55
	DK 60

ZHK-104 Yıldız Kaplin Lastiği

Star Coupling Plastic
Резина Звездобразной Муфты



Code	Type
ZHK-104	90
	110
	130
	150
	180
	200

ZHK-106 Zincir - Kilit - Yarım Ek

Chain - Lock - Semi Supplement
Цепь-Замок-Дополнительный Замок



Code	Type	Pitch	Chain	Lock	Half Join
ZHK-106	Z / 01	3/8"	I-II-III	I-II-III	I-II-III
	Z / 02	1/2"	I-II-III	I-II-III	I-II-III
	Z / 03	5/8"	I-II-III	I-II-III	I-II-III
	Z / 04	3/4"	I-II-III	I-II-III	I-II-III
	Z / 05	1"	I-II-III	I-II-III	I-II-III
	Z / 06	1x1/4"	I-II-III	I-II-III	I-II-III
	Z / 07	1x1/2"	I-II-III	I-II-III	I-II-III
	Z / 08	1x3/4"	I-II-III	I-II-III	I-II-III
	Z / 09	2"	I-II-III	I-II-III	I-II-III
	Z / 10	2x1/2"	I-II-III	I-II-III	I-II-III



DÜŞÜK BASINÇLI FAN (TOZ ASPIRATÖR)

Low Pressure Fan (Dust Aspirator)
Вентилятор

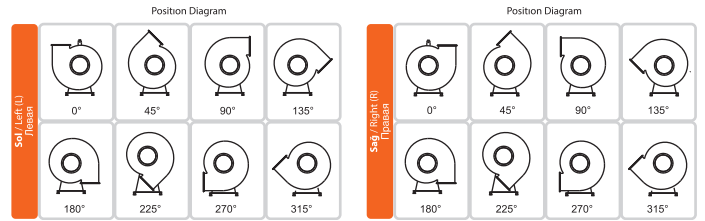
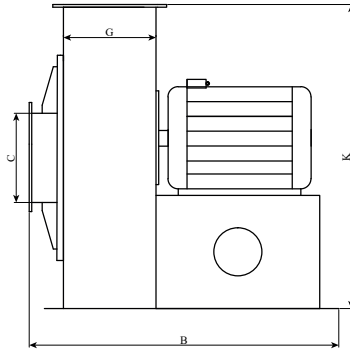
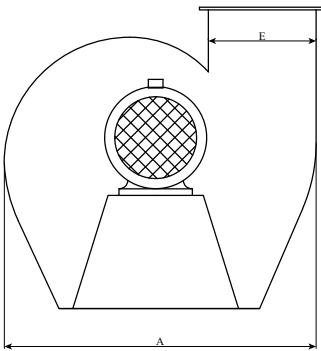

TYPE	C	K	E	G	A	B	Power (kW)	RPM
ZTA 5,5	350	820	350	300	896	790	5.5	1500
ZTA 7,5	360	1142	426	400	1224	910	7.5	1500
ZTA 11	425	1203	476	450	1326	1060	11	1500
ZTA 15	475	1268	530	500	1432	1110	15	1500
ZTA 18,5	420	1215	424	400	1332	1010	18.5	1500
ZTA 22	450	1550	524	400	1440	1010	22	1500

TOZ SIKLONU

Dust Cyclone
Циклон Пыли

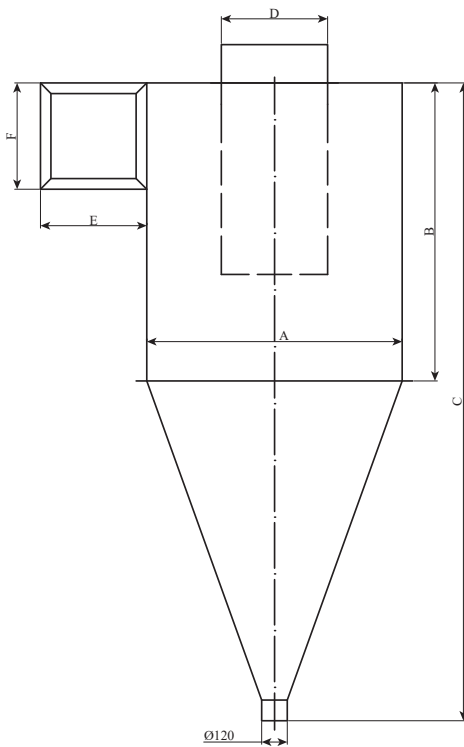

TYPE	ZTS 80	ZTS 100	ZTS 120	ZTS 135	ZTS150
A	800	1000	1200	1350	1500
B	1250	1300	1400	1450	1500
C	2050	2200	2700	2950	3150
D	250	300	500	550	600
E	250	300	400	450	500
F	250	300	400	450	500
AIR (m ³ / min)	1.2	1.8	2.4	3.3	4.1



divayn
FEVZİ



ZORLU DEĞİRMEN
DEĞİRMEN MAKİNELERİ İML. SAN. LTD. ŞTİ.

Fevzi Çakmak Mah. Gülistan Cd. No: 36/A Karatay / KONYA
Tel +90 332 248 10 83 // Fax +90 332 248 10 88 // info@zorumilling.com

www.zorumilling.com

